

Réf. imp. 046022 / A7-1 - PAS DE NOTICE

**22****SUPRA 22**111 8669  
ART : 79022**Max. 75 Kg****SUPRA 22**

FORD Fiesta / MAZDA 121 :

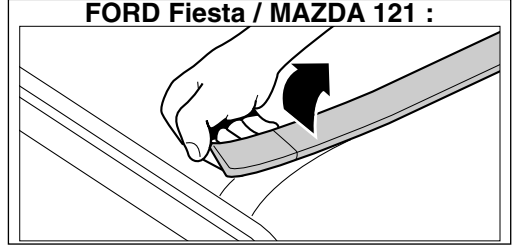

4,5 □

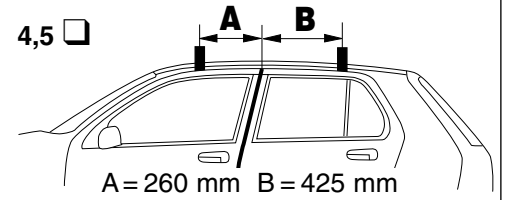

3 □

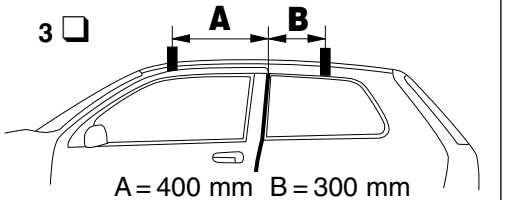
**DAEWOO**

FORD Escort Van, Sierra, Sapphire  
 MITSUBISHI / OPEL  
 VAUXHALL/CHEVROLET/RENAULT

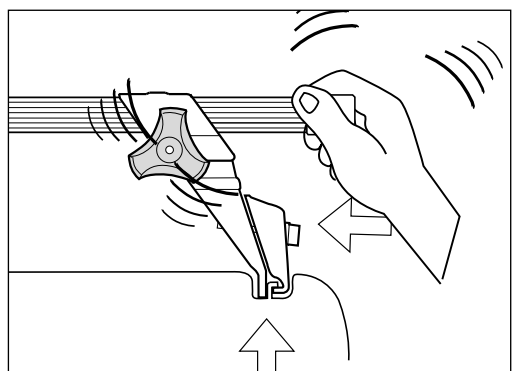
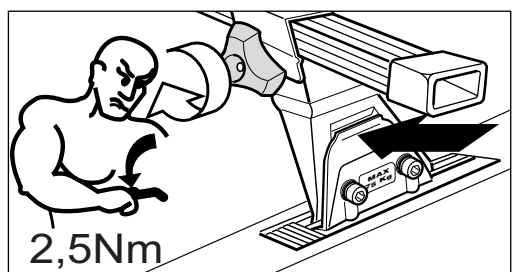
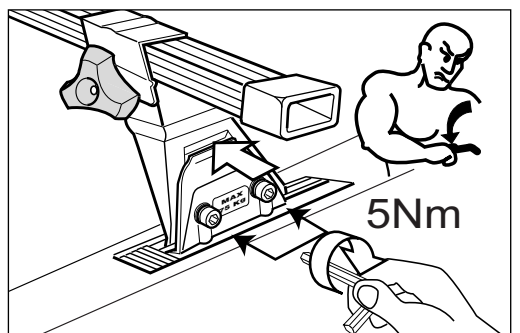
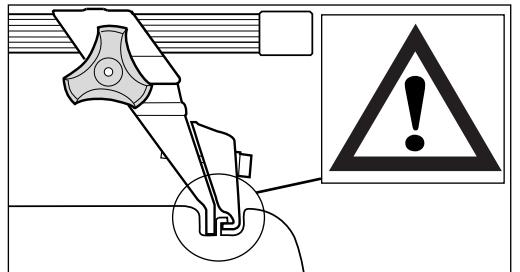
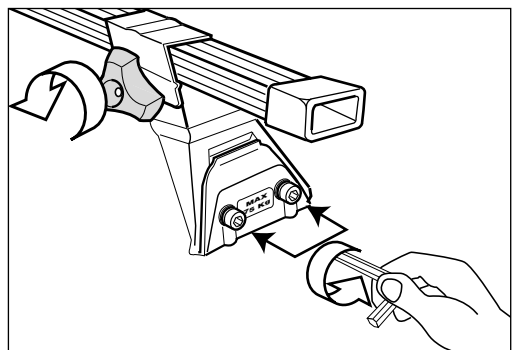
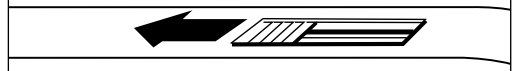

**AUTOMAXI INTERNATIONAL**  
 Z.I Nord - 24 Rue Claude Bernard - CS 61768  
 35417 Saint Malo Cedex - France  
 Tél : 33 (0) 2 99 21 12 70 - Fax : 33 (0) 2 99 21 12 71

**DAEWOO**  
 Nexia 3, 4, 5 □ 95→

**FORD**  
 Escort Van 3 □ 91→  
 Fiesta 3, 5 □ 89→04/02<sup>(2)</sup> / 3, 4 □ 00→  
 Sierra 4 □ 87→99

**MAZDA**  
 121 3, 5 □ 96→

**MITSUBISHI**  
 Carisma 4, 5 □ 96→  
 Colt 3 □ 98→  
 Galant 4 □ 88→97  
 Galant Liftback 5 □ 93→97

**OPEL/VAUXHALL/CHEVROLET**  
 Astra 3, 4, 5 □ & 5 □ Break\* 92→97  
 Astra II 2 □ 00→  
 Astra II 3, 4, 5 □ 98→02/04  
 Calibra 3 □ 90→98  
 Corsa 3, 5 □ 93→99  
 Corsa III 3, 5 □ 00→09/06  
 Kadett 3, 5 □ 85→91  
 Tigra 3 □ 94→  
 Zafira 5 □ 99→08/05<sup>(2)(9)</sup>

**RENAULT**  
 Mégane Break\* 5 □ 99→09/03

□ = portes / Doors / Türiq / porte / Puertas / drzwi / Deurs / Portas /  
 Ајтóкћоэ / двери / πόρτες

(2) Véhicule sans barres longitudinales d'origine - Vehicle without  
 original longitudinal bars - Fahrzeuge ohne original-dachreling - Veicoli  
 senza barre longitudinali originali - Vehículo sin barras longitudinales de  
 origen - Samochód bez oryginalnych relingów - Voertuig zonder  
 originele longitudinale stangen - Veículo sem barras longitudinais de  
 origem - Gyárilag hosszirányú rudak nélkül szerelt gépjármű -  
 Автомобиль без продольных дуг, предусмотренными моделью -  
 Όχημα χωρίς διαμήκεις μπάρες από εργοστασιακή κατασκευή.

(9) = Avec trappes dans les baguettes de toit. With traps in roof strakes,  
 Mit Klappen in den Dachleisten, Con fermi a innesto nelle barre sul tetto,  
 Con trampillas en las varillas de techo, Z otworami w listwach  
 dachowych, Met schuifjes in de dakstrips, Com alçarões nas varetas de  
 tejadilho, Gyári nyílással a tető peremén, Со штатными отверстиями в  
 продольных дугах на крыше автомобиля, Με ειδικές υποδοχές  
 στήριξης στις μπαγκέτες οροφής.